

RM30 BLIZZARD

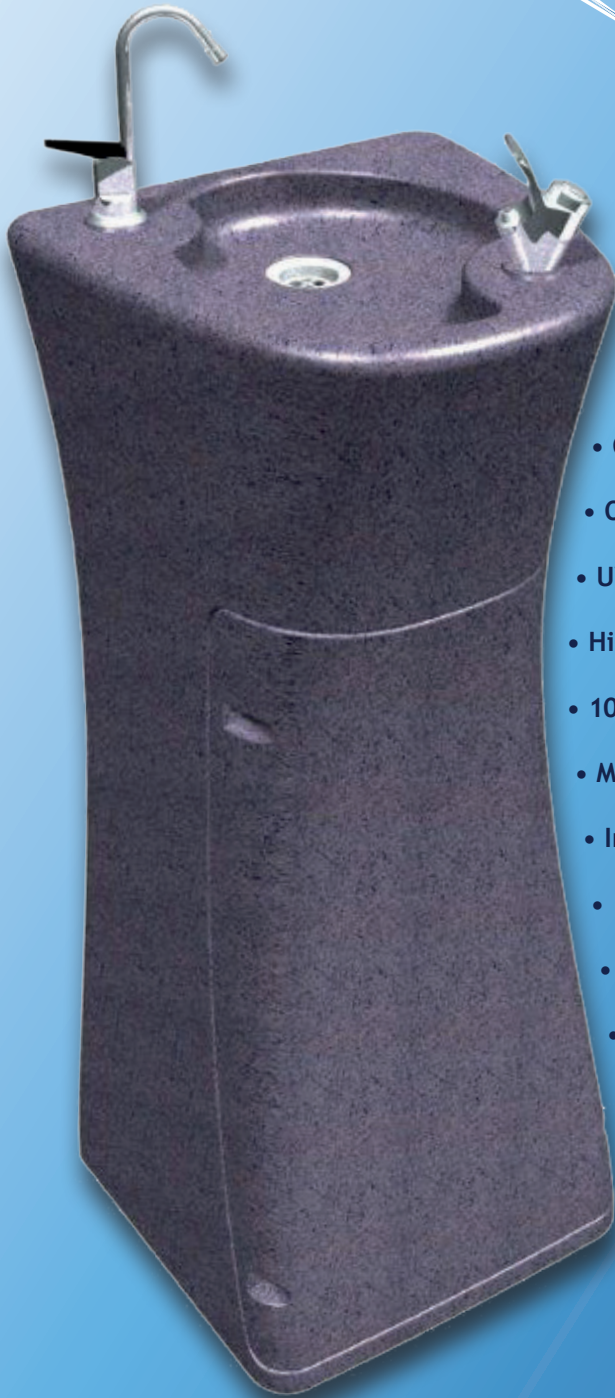

The thirst quenchers!



- Optional Filtration
- Optional Glass Filler
- UV Stabilised Cabinet
- High Cooling Capacity
- 100% Rust Proof Cabinet
- Modern Granite Look Finish
- Impact Resistant Construction
- 12 Month Comprehensive Warranty
- Designed in Australia by Waterworks®
- Pressure Reducing Valve and Shock Arrestor - protect from water mains pressure surges

Design Registration
No. 158110.

Unit depicted has optional Glass Filler fitted.



RM30 BLIZZARD

GENERAL FEATURES

RUST PROOF CABINET

The RM Blizzard cabinet is made of roto-moulded, pigmented polyethylene. This U.V. stabilised material provides an external cabinet which is durable, modern and 100% rust proof.

SERVICE ACCESS

The front access panel is secured with four (4) concealed stainless steel screws. Removal of this panel provides access for any purpose including service, maintenance and filter replacement.

VANDAL RESISTANCE

The top and basin on the RM Blizzard is a single piece, (not numerous parts screwed together). This, combined with the internally fitted drain grill and the robust nature of polyethylene, provides unequalled vandal resistance.

IP RATING - IP rating 23

CHILLING TANK - 1.9L stainless steel chilling tank.

OPTIONAL FEATURES

FILTRATION

An internal or external Waterworks filter will reduce sediment, chemicals, organic compounds and impurities which can adversely affect the quality and taste of your drinking water. If filter is required, please specify "Filtered" on order.

TEMPORARY DRAIN KIT

1.5mtr temporary drain kit is available for temporary installations such as construction sites.

INSTALLATION CONNECTIONS

ELECTRICAL

A 1.5 metre cordset with standard 3 pin plug is provided. Power consumption Ambient Temp 25deg. (kw.h/24h) 0.044.

WATER INLET

The inlet is an industry standard 1/2" female BSP threaded connection situated on the rear of the cooler, (see installation instructions for exact rough in details).

DRAIN OUTLET

The drain outlet and integrated 'P' trap provide an industry standard 40mm connection situated on the rear of the cooler. (see installation instructions for exact rough in details).

WARRANTY

The warranty provides comprehensive parts and labour coverage, for the period of 12 months from the date of original sale.

SHIPPING DETAILS

PACKED WEIGHT: 28kg

PACKED VOLUME: 0.208M3

PACKED DIMENSIONS: 420mmW x 420mmD x 1180mmH

ORDERING CODES

CODE	DESCRIPTION
RM30B	RM Blizzard with bubbler tap only
RM30GF	RM Blizzard with bubbler tap and glass filler

CAPACITIES CHART

MODEL NUMBER	AMBIENT TEMP	INLET TEMP	LITRES/HR 10°C WATER	RESERVOIR VOLUME
RM30	32°C	27°C	30 LPH	1.9 Litre

* Based on intermittent use under environmental conditions of ARI Standard 1010 and installation requirements of ARI Standard 1020.

** Due to our policy of continuous development, specifications are subject to change without notice.

*** Colour is as close to actual as printing processes allow.

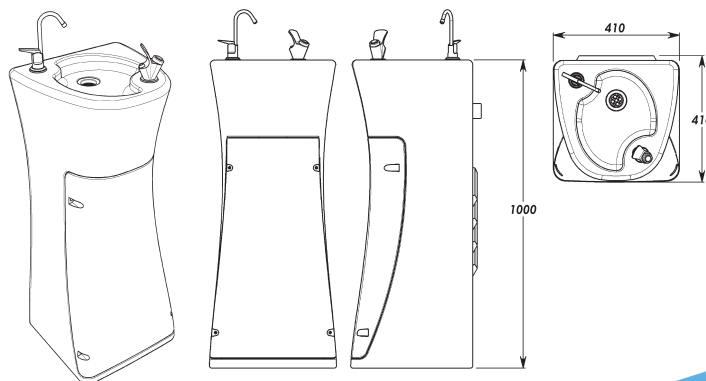

Distributed by...

Waterworks Australia

ABN 91 902 793 936

48 Neumann Road Capalaba Queensland 4157

Phone (07) 3390 3777 • Fax (07) 3390 1766

Email sales@waterworksaustralia.com

www.waterworksaustralia.com

As part of Waterworks Australia's policy of continuous improvement, we reserve the right to alter specifications at anytime without notice.